

GS 630



Operating Manual

Winterhalter GS 630 Utensil Washer

1 Table of contents

1	Table of contents	25
2	Safety notes	25
3	Before working with the machine	27
4	Rinse aid and detergent	28
5	Machine description	30
6	Operation	32
7	Servicing and maintenance	36
8	Decommissioning for long durations	39
9	Malfunctions	40
10	Emission values	42
11	Disposal	42
12	Installation	42
13	Water connection	42
14	Electrical connection	43
15	Position of the dosing points (detergent, rinse aid, defoamer)	44
16	Connecting external dosing devices	45
17	Connection diagram GS 630	46
18	Installation plan GS 630	47
19	Total connected loads GS 630	48
20	Niche dimensions GS 630	48

2 Safety notes

Please read through the safety notes carefully that have been listed here for safe handling of the GS 630 Utensil Washer.

2.1 Explanation of symbols used

The following symbols have been used in this manual:



Danger

Warning against potential serious or fatal injuries to persons if the described precautionary measures are not taken.



Warning

Warning against potential minor injuries to persons or potential material damage if the described precautionary measures are not taken.



Caution

Warning against defects in or destruction of the product if the described precautionary measures are not taken.

INFO

This is a useful tip.



These arrows indicate handling instructions



This symbol indicates the results of your handling



This symbol indicates enumerations



This symbol refers to a chapter with more detailed information

2.2 Proper use

- Use the GS 630 Utensil Washer only for washing dishes and other equipment used for cooking and other related activities (butchery, bakery).
- The GS 630 Utensil Washer is a technical device for commercial use and is not intended for private use.
- Always use washing racks that are suitable for the dishes. Do not wash without a washing rack.

2.3 Improper use

- This device is not intended for use by persons (including children) with limited physical, sensory or mental capabilities or who do not have the required experience with and knowledge of this device. Such persons must either be instructed by a supervisor who is responsible for their safety or must be supervised during the operation of the device.
- Do not use the device to wash electrically heated devices or parts made of wood.
- Do not wash parts made of plastic if they are not heat and lye-resistant.
- Use a suitable detergent to wash parts made of aluminium such as jars, containers or plates in order to prevent black stains.
- Winterhalter Gastronom GmbH does not assume liability for any damage caused due to improper use of the device.

2.4 Using chemicals (detergents, rinse aids, descalers...)

- When handling chemicals, observe the safety notes and dosing recommendations printed on the packing.
- Wear protective clothing, protective gloves and protective goggles when handling chemicals.
- Use only products that are suitable for industrial dish washers. Such products are appropriately marked. We recommend Winterhalter products. These are especially adapted to Winterhalter dish washers.
- Do not mix different detergents in order to prevent efflorescence which could destroy the detergent dosing device.
- Do not use products that can create foam, e.g. hand soap, soft soap, hand wash liquid. Ensure that these do not enter the dish washer even during the pre-treatment of the utensils.

2.5 General safety notes

- Read through the safety notes and operating instructions in this manual carefully. Winterhalter Gastronom GmbH does not assume liability or warranty in case of non-adherence to these safety notes.
- Use the dish washer only after you have read and understood the operating manual. Allow the Winterhalter Customer Service Department to provide information about the operation and functioning of the dish washer. Always operate the machine as described in this operating manual.
- Train the operating personnel as regards handling the machine and inform them about the safety notes. Repeat the training sessions at regular intervals to prevent accidents.
- Do not make changes, additions or reconstructions in the dish washer without the approval of the manufacturer.
- In case of danger and/or defects, switch off the machine immediately. Switch off the local mains separator (main switch). Only then is the machine without power.
- Contact the Winterhalter Customer Service in case of defects that are not caused due to the local water or the current supply line. In case of defects resulting from an unknown cause, switch off the machine, and switch it on again only when the defect has been rectified.
- For your safety, test the local fault current circuit breaker (FI) regularly by pressing the test button.
- Keep the machine documents accessible. The service engineers authorised by Winterhalter require the circuit diagram for repairs.
- The dish washer may not be exposed to explosive or frost-endangered areas.
- Keep the dish washer away from children. The interior space of the dish washer contains lye-mixed hot water with a temperature of approx. 60°C. The water in the dish washer is not drinking water.
- Close the local water shut-off valve after the work is complete.
- Switch off the local mains disconnecter after the work is complete.
- Do not open the machine door when the machine is in operation. There might be a risk of the lye-mixed hot water spilling out. Stop the washing programme before doing so (► 6.3).

2.6 Daily cleaning and maintenance

- Adhere to the servicing and maintenance instructions in this manual (► 7).
- Wear protective clothing and protective gloves before touching parts with detergent solution (filters, wash arms, ...).
- Do not spray the machine and the surrounding area (panels, base) using a water hose, steam-jet air ejector or high-pressure cleaner.
Ensure that the plinth of the machine is not flooded when washing it in order to prevent an uncontrolled inflow of water.
- Use a brush or a cloth and not a high-pressure cleaner when cleaning the inside of the machine.
- Do not use a scrubbing agent or an abrasive cleaner.
- During the daily cleaning process, ensure that there are no rusty external bodies in the machine which can cause the "stainless steel rust-free" material to start rusting. Rust particles can come from non-rust-free cleaners, damaged wire racks or non-rust-protected water lines.
- Clean and maintain the external areas using a suitable stainless steel cleaner and a soft cloth. We recommend Winterhalter Gastronom stainless steel cleaners and stainless steel supports.

3 Before working with the machine

- Get the machine installed by your service engineer or authorised Winterhalter dealer. More information is provided in chapter 12. If the install location is not frost-free, adhere to chapter 8.
- Get the machine connected as per the locally applicable standards and the regulations of the authorised mechanics (water, waste water, electrical system). More information is provided in chapters 13 and 14.
- Get the machine commissioned by a service engineer authorised by Winterhalter. Get yourself and your operating personnel trained in the operation of the machine.

3.1 Checking the completeness

- Check the delivery on the basis of the delivery note for completeness and transport damage.
- In case of any damage, inform the shipper, the insurance agency and the manufacturer about it.

3.2 Commissioning

- After connecting the water and the current properly, contact the relevant Winterhalter dealer or your dealer for the commissioning of the machine and for providing training in its operation.

4 Rinse aid and detergent

4.1 Safety notes

**Warning**

When handling chemicals, observe the safety notes and dosing recommendations printed on the packing.

Wear protective clothing, protective gloves and protective goggles when handling chemicals.

**Caution**

Use only products that are suitable for industrial dish washers. Such products are appropriately marked. We recommend Winterhalter products. These are especially adapted to Winterhalter dish washers.

Do not mix different detergents in order to prevent efflorescence which could destroy the detergent dosing device (► 4.4)

Do not fill rinse aids in the storage containers for detergents and vice versa.

Do not use products that can create foam, e.g. hand soap, soft soap, hand wash liquid. Ensure that these do not enter the machine even during the pre-treatment of the utensils.

4.2 Rinse aid

A rinse aid is necessary to ensure that water on the dishes drains off after washing and dries off after a short while. Rinse aids are automatically supplied from a storage container outside the machine into the boiler of the machine. The rinse aid dosing device is an in-built component of the machine. The service engineer authorised by Winterhalter sets the dosing amount when commissioning the machine.

INFO: The rinse aid dosing device is not included in the scope of delivery of all machines.

The storage container for the rinse aid must be equipped with a suction tube with level monitoring if the level of the rinse aid in the machine is to be displayed.

4.3 Detergent

A detergent is necessary to ensure that the leftovers and dirt on the dishes is cleaned. Detergents can be supplied as follows:

- Manually as detergent powder.
- Automatically from a storage container outside the machine via a detergent dosing device that is either built in the machine or is installed outside it.

INFO: The detergent dosing device is not included in the scope of delivery of all machines.

Dosing of the detergent powder

Pre-dosing

- Fill approx. 50 g detergent powder into the machine when the programme key (6) lights up in green.
- Then start a wash cycle immediately in order to mix the detergent powder with the water.
- Adhere to the dosing instructions on the packaging of the detergent.

Post-dosing

- Fill approx. 50 g detergent powder into the machine after 5 wash cycles.

Post-dosing for machines with manual or automatic cold water pre-wash

- Note that the detergent concentration reduces more quickly in case of cold water pre-wash.
- Thus, supply a greater quantity in case of constant use of cold water pre-wash.

Dosing of liquid detergent

The service engineer authorised by Winterhalter sets the dosing amount when commissioning the machine.

The storage container for the detergent must be equipped with a suction tube with level monitoring if the level of the detergent in the machine is to be displayed.

4.4 Changing the detergent (liquid detergent)

- When changing the detergent, adhere to the following:
 - Mixing different detergents can lead to efflorescence that can lead to a failure of the detergent dosing device. This is applicable even if the new detergent is from the same manufacturer.
 - A new detergent usually requires a new setting of the detergent dosing device.
 - The dosing pipe and the detergent dosing device must be thoroughly rinsed with water before the new detergent is used.
- Assign the required work to a service engineer authorised by Winterhalter to attain good results.

If this is not done, the warranty and product liability of Winterhalter Gastronom GmbH expires.

This is how you should rinse the dosing pipe and the detergent dosing device:



Warning

When handling chemicals, observe the safety notes and dosing recommendations printed on the packing.

Wear protective clothing, protective gloves and protective goggles when handling chemicals. Do not mix different detergents.

- Remove the suction pipe from the storage container with the currently used detergent and place it in a container filled with water.
- Initiate several washing programmes till the water is supplied to the machine via the detergent dosing device. The suction and pressure pipes are rinsed here.
- Place the suction pipe in the storage container with the new detergent.

5 Machine description

5.1 Operating panel

The operating panel is to the right of the machine door.

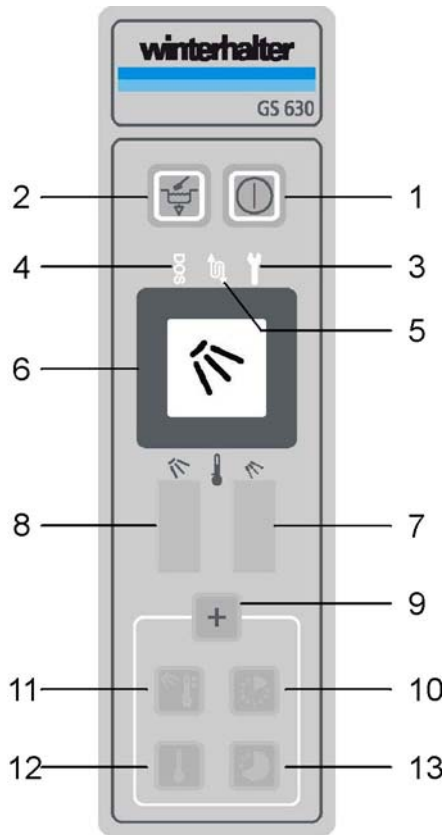

- 1 On-off switch
- 2 Tank draining / self-cleaning
- 3 Indicator light for defect
- 4 Indicator light for insufficient detergent or rinse aid¹
- 5 Indicator light for exhausted water supply if this can be determined from the water consumption
- 6 Normal washing cycle
- 7 Temperature indicator for boiler (when the machine is warming up and if special programmes are activated)
- 8 Temperature indicator for tank (when the machine is warming up and if special programmes are activated)
- 9 Function key; activates special programmes (10-13)
- 10 Short washing cycle
- 11 Temperature switching for rinsing (optional)
- 12 Cold water pre-wash (optional)
- 13 Intensive washing cycle

5.2 Mode of operation

The boiler and the tank fill up and are warmed up to the operating temperature after the machine is switched on. The programme key (6) lights up in red during the warm-up phase.

When the desired temperatures (tank: approx. 60°C, boiler: approx. 85°C) are attained, the machine is ready for operation. The start key (6) lights up in green.

The machine is operated with fully automatic programmes consisting of the programme steps Wash, Drain and Rinse. The programme key (6) lights up in blue during the programme.

The rinse aid is usually supplied via an in-built dosing device. The storage container for the rinse aid is placed outside the machine.

Depending on the design of the machine, the rinse aid is supplied either manually (powder) or via an in-built or external dosing device (liquid detergent). The storage container for the detergent is placed outside the machine.

¹ Shows a defect in the detergent or the rinse aid if external drums with suction pipe and level monitoring are used.

The indicator light flashes as soon as an empty drum is detected. If the drum has not been re-filled or replaced after 20 washing processes, the indicator light lights up and the installed dosing device (if any) is switched off.

Programme steps

Wash: The circulating pump supplies the detergent solution from the tank to the dishes via the wash arms and nozzles. Here, the wash arms move which ensures powerful and effective cleaning of the dishes. During rotation, detergent solution is constantly supplied via a filter system and the patented Mediamat Cyclo (separator for suspended parts).

Drain: After washing, there is a short break which allows the detergent solution to drain off from the dishes.

Rinse: In the last programme step, the washed dishes are rinsed with fresh hot water to remove lye remains and to warm up the dishes for optimum drying outside the machine. The rinsing water also replaces the detergent solution.

Cold water pre-wash: The dishes are also optionally rinsed with cold water before the first programme step in order to prevent coagulation of albuminous dirt. Depending on the structure of the machine, this is done automatically either before every wash cycle or after the activation of this function.



Warning

Do not open the doors during the washing programme. There is the risk of hot water spilling out of the device.

Do not keep the doors open.

5.3 Washing programmes

The dish washer can be operated in several modes. The mode is selected via the operating panel.

Mode	Explanation
Normal programme (6)	for medium dirty dishes medium drying time
Short programme (10)	for slightly dirty dishes short / no drying time
Option: Programmes with reduced rinsing temperature (11)	For washing glasses Programme duration: Depending on the selected washing programme
Intensive programme (13)	for heavily dirty dishes Long drying time
Option: Normal programme with cold water pre-wash (12)	For dishes with albuminous dirt Coagulation is prevented by rinsing with cold water
Tank draining / self-cleaning (2)	Cleaning the machine: <ul style="list-style-type: none"> – Circulation of the detergent solution within the washing compartment – Pumping the detergent solution – Rinsing the washing compartment with hot fresh water – Pumping out the used fresh water. The washer switches off automatically after the washing cycle is complete

6 Operation

6.1 Switching on

6.1.1 Before switching on the machine

- Open the local water shut-off valve.
- Switch on the local mains disconnecter.
- For your safety, test the local fault current circuit breaker (FI) by pressing the test button.
- Open the machine door and check whether the wash arms (3 above, 3 below) and the filters (3 strainers, 1 filter cassette) have been installed.
- Check whether the lower rinse pipes are folded downward.
- Close the machine door.



Warning

When handling chemicals, observe the safety notes and dosing recommendations printed on the packing.
Wear protective clothing, protective gloves and protective goggles when handling chemicals.
Do not mix different detergents.

- Check whether detergent and rinse aid are present in the storage containers. Refill on time or replace the storage containers so that the washing result is not affected.

6.1.2 Switching on the machine and making it ready for operation

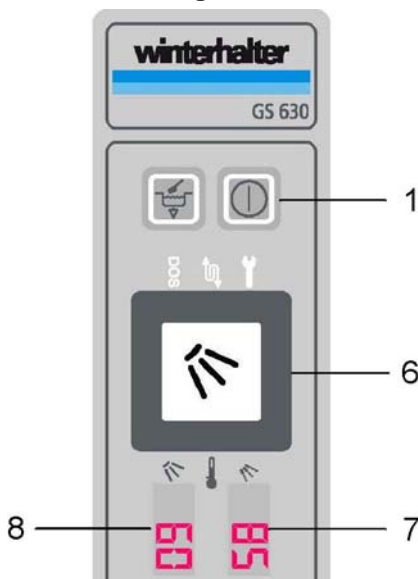

- Close the machine door
- Press the on-off switch (1)
 - ⇒ The programme key (6) lights up in red
 - ⇒ The tank of the machine is automatically filled and heated.
 - ⇒ Detergent is supplied to the tank of the machine (provided a dosing device is connected).
 - ⇒ The temperatures in the boiler (indicator 7) and tank (indicator 8) are displayed till the desired temperatures are reached. After that, the display switches off.

If the programme key (6) lights up in green, it means that the machine is ready for operation.

6.1.3 Supplying detergent manually

- Follow the chapter 4.

INFO: If the washer is equipped with an installed or an external detergent dosing device, detergent does not need to be supplied manually.

In case of an external detergent dosing device, adhere to the relevant operating manual.

6.2 Washing

6.2.1 Sorting the dishes



Adhere to the following:

- Soak the dried residues
- Soak the cutlery till it is rinsed
- Position knives and other sharp and pointed cutlery in the cutlery stand with the handle outside in order to prevent injuries
- Position plate racks and other racks with the outer dimension 500 x 500 mm on the utensil rack for washing
- Light plastic parts may slip or turn when washing. Place a plastic rack on these light parts



Caution

Excessive dirt can lead to the filter system clogging and the washing programme being disturbed.

- Remove large leftovers
- Pour away sauce remains

6.2.2 Washing with the normal washing cycle



- Close the machine door.
- Press the programme key (6).
 - ⇒ The programme key (6) **lights up in blue** during the programme.
 - ⇒ The programme key (6) **flashes in green** if the programme is ended and the door is closed. If the door is opened to pull out the washing rack, the programme key (6) lights up in green. The programme key (6) flashing in green shows that the washing programme has ended but the doors have not been opened.
- Open the machine door.
- Pull out the washing rack.

6.2.3 Break

- Check the filter cassette for dirt and clean it if required. The filter cassette can be removed without draining the tank.
- Check the tank water for dirt. If required, drain it and refill the machine.
- Close the doors.

6.2.4 Washing with special programmes

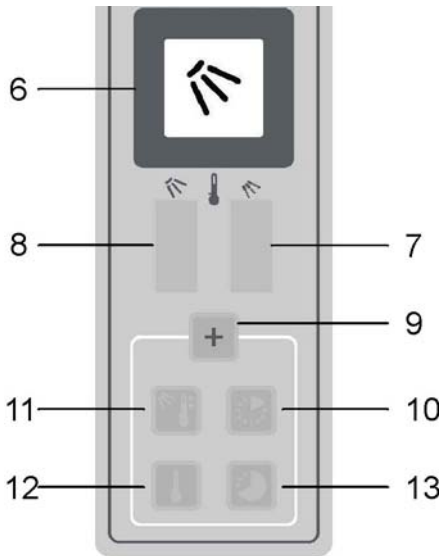

- Press the function key (9).
 - ⇒ The special programmes (10, 11, 12, 13) are also available in addition to the normal programmes (6).
 - ⇒ The number depends on the design of the machine. All lit keys can be selected.
 - ⇒ Temperatures in the tank (8) and boiler (7) are displayed (but not during the washing).
- Press the function key (9) to deactivate the special programmes.

6.2.5 Special programmes

Key 10

Short programme

for slightly dirty dishes
short / no drying time

Activate mode: Press button 10

Start mode: Press button 6

The special programme remains saved till another special programme is selected or key 9 is pressed.

Key 11

Programmes with reduced rinsing temperature (optional equipment)

For washing glasses

Activate mode: Press button 11

The rinsing temperature is displayed in display 7.

The first wash cycle is carried out with high rinsing temperature.

Start mode:

Short programme: Press key 10 and then key 6

Intensive programme: Press key 13 and then key 6

Normal programme: Press button 6

⇒ Key 11 flashes till the washing is carried out with reduced rinsing temperature.

At the end of the mode:

Press key 11 or key 9 again to deactivate the reduction in the rinsing temperature.

Key 13

Intensive programme

for heavily dirty dishes
Long drying time

Activate mode: Press button 13

Start mode: Press button 6

The special programme remains saved till another special programme is selected or key 9 is pressed.

Key 12

Mode with manual cold water pre-wash (optional equipment)

For washing cutlery with albuminous dirt (meat and blood remains).

The cutlery is first rinsed with cold water and then cleaned in the normal programme. This prevents the coagulation of the albuminous dirt.

Activate mode: Press button 12

Keys 10 and 13 are no longer lit and cannot be selected.

Start mode: Press button 6

⇒ Key 12 flashes till the cold water pre-wash is on.

At the end of the mode:

Press key 9 again to deactivate the cold water pre-wash.

6.2.6 Routine checks

- Check whether the dishes are clean.



- Check whether the indicator light for defects has lit up on the operating panel.

If yes:

- Switch off the machine and note the error code
- Using the error table in chapter 9.1, check whether the error can be rectified by you
- If no, forward the error message to the Winterhalter service engineer
- Switch on the machine only after the error has been rectified

DOS

- Check whether the indicator light for insufficient detergent or rinse aid has lit up on the operating panel

If yes:



Warning

When handling chemicals, observe the safety notes and dosing recommendations printed on the packing.
Wear protective clothing, protective gloves and protective goggles when handling chemicals.
Do not mix different detergents

- Check whether detergent and rinse aid are present in the storage containers. Refill or replace the storage containers on time so that the results of washing are not affected.
- Check the interior of the machine



Warning

Wear protective clothing and protective gloves before touching parts with detergent solution (filters, wash arms, ...)



Open the machine door



Fold the lower rinsing pipes upward



Remove the lower wash arms and if necessary, clean them



Remove the filter cassette and the strainers



Clean the filter cassette



Clean the strainers



Mount the filter cassette and the strainers



Mount the lower wash arms



Fold the lower rinsing pipes downward



Close the machine door

6.3 Switch off the machine

- Press the on/off key (1).
 - ⇒ The keys are no longer lit and the machine is switched off. The tank remains filled but the temperature is not maintained.



Warning

The machine is without power only if the local mains disconnecter has been actuated.

- If at the end of a working day, you drain the tank and want to clean the machine, proceed as described in chapter 7.1.

7 Servicing and maintenance



Warning

Do not spray the machine and the surrounding area (panels, base) using a water hose, steam-jet air ejector or high-pressure cleaner. Ensure that the base of the machine is not flooded when washing it in order to prevent an uncontrolled inflow of water.

7.1 Daily

A self-cleaning programme is helpful in cleaning the machine.

7.1.1 Starting the self-cleaning programme

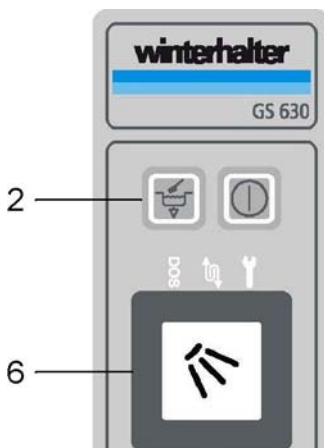

- Open the machine door.
- Take the dishes out of the machine.
- Close the machine door.
- Press key 2 for approx 2 seconds and then release it.
 - ⇒ Key 2 flashes
 - ⇒ Key 6 is not lit
 - ⇒ The self-cleaning programme clean the machine from the inside.

When the self-cleaning programme is complete, the washer switches off automatically. The operating panel is no longer lit.

7.1.2 Manual cleaning of the machine interior



Open the machine door



Fold the lower rinsing pipes upward



Remove the lower and upper wash arms



Remove the filter cassette and the strainers



Clean the filter cassette



Clean the strainers



Clean the wash arms

If the interior of the machine is dirty: Clean the interior with a sponge and a brush. If necessary, spray it using a hose.

Clean the sieves from the pump suction openings using a brush. The sieves can be removed if required.



Mount the filter cassette and the strainers



Mount the lower and upper wash arms



Fold the lower rinsing pipes downward



Close the machine door

- Press the on/off key (1) to switch on the machine
- Press key 2 for approx 2 seconds and then release it
 - ⇒ The water in the tank is pumped out and the machine then switches off
- Close the local shut-off valve for the water supply
- Switch off the local mains disconnecter

7.1.3 Cleaning the exterior of the machine

- Clean the external surfaces using a stainless steel cleaner and stainless steel support.
- Open the machine door a little so that the interior can dry. This is important for long-term corrosion protection even in case of stainless steel.

7.1.4 Checking the external water preparation

- Check whether sufficient regenerating salt has been filled

7.2 Monthly

7.2.1 Cleaning the dirt trap

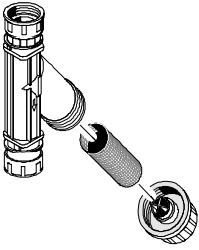

- Close the shut-off valve for the water supply
- Clean the dirt trap

7.2.2 Descaler

If the machine is operated with hard water without the relevant water preparation, the boiler, the machine interior and all water lines can scale.

Grease residues and the dirt and grease remains in them are a great risk as regards hygiene and scaling can lead to failure of heating elements. Regular removal of these layers is absolutely essential.

In order to be able to descale all water lines and the boiler properly, assign this work to a Winterhalter service engineer.

You can descale parts of the interior of the machine yourself with the help of the following notes.

- Drain the machine (▶ 7.1)
- Stop the detergent dosing (e.g. remove the suction pipe or switch off the detergent dosing device) in order to prevent formation of chlorine if detergents containing active chlorine and descalers get mixed.
- Fill the machine (▶ 6.1)
- Wait till the machine is ready for operation



Warning

When handling chemicals, observe the safety notes and dosing recommendations printed on the packing.

Wear protective clothing, protective gloves and protective goggles when handling chemicals.

- Supply the recommended dose of the descaler in the machine tank
- Trigger the intensive mode once or twice
- Drain the machine (▶ 7.1)



Caution

The descaler may not remain in the machine for hours.

- Fill the machine (▶ 6.1)
- Trigger the intensive mode once or twice to remove the remaining descaler from the washing system
- Drain the machine again (▶ 7.1)
- Restart the detergent dosing

7.3 Maintenance by the Customer Service

We recommend that you have a Winterhalter service engineer carry out the maintenance of the machine at least twice a year so that venerable parts can be checked and replaced accordingly.

Such components include:

- Water supply pipes
- Dosing pipes

Winterhalter has a maintenance contract that includes these services.

8 Decommissioning for long durations

Follow the notes if the machine needs to be out of operation for a long duration (holidays, seasonal business).

- Drain the machine (► 7.1)
- Clean the machine as described in chapter 7
- Keep the machine door open
- Close the local shut-off valve of the water supply line
- Switch off the local mains disconnecter

If the machine is in a place that is not frost-free:

- Assign a Winterhalter service engineer with the task of making it frost-resistant:
 - The engineer must drain the boiler, the rinsing pump and the drain pump.

Re-commissioning

After the break, the machine must be in a completely assembled condition (at a temperature of 25°C for at least 24 hours) before it is put into operation again.

- Open the local shut-off valve of the water supply line
- Switch on the local mains disconnecter
- Switch on the machine

9 Malfunctions

This chapter explains the remedies in case of malfunctions. The causes and remedies have been specified in the tables. Contact the Winterhalter service engineer if you cannot eliminate the error yourself.





Danger

DANGER! Danger of life due to components that are energised!

Do not open any machine covers or machine parts if it requires tools. There is danger of shock. Let a Winterhalter service engineer carry out work on the electrical system. The machine must first be disconnected from the mains.

9.1 Malfunctions; display on the operating panel

Display	Meaning	Remedy
DOS	Insufficient detergent or rinse aid	<ul style="list-style-type: none"> ➤ Refill the detergent or rinse aid
	Error message	<ul style="list-style-type: none"> ➤ Switch off the machine <ul style="list-style-type: none"> ⇒ An error code is displayed on the operating panel <p>If Err 4, Err 5, Err 7-Err 10, Err 15 or Err 17-Err 18 is displayed:</p> <ul style="list-style-type: none"> ➤ Check whether the water shut-off valve is open ➤ Switch on the machine again <p>If there is an error message:</p> <ul style="list-style-type: none"> ➤ Disconnect the machine from the mains and close the water shut-off valve ➤ Forward the error message to the Winterhalter service engineer <p>If another error code is displayed:</p> <ul style="list-style-type: none"> ➤ In this table, check what the error code means then follow the notes
Err 1 Err 12 Err 13	If error code Err 1, Err 12 or Err 13 is displayed, it means that there is a machine malfunction due to which the machine automatically switches off and can no longer be switched on.	<ul style="list-style-type: none"> ➤ Forward the error message to the Winterhalter service engineer
Err 6	Machine-internal error or water supply blocked	<ul style="list-style-type: none"> ➤ Inform the Winterhalter Customer Service or get the blockage rectified.
Err 21	If the error code Err 21 is displayed when the machine is switched off, it means that the water level in the machine was too high. Water was thus pumped off.	<ul style="list-style-type: none"> ➤ Close the water shut-off valve so that water no longer flows into the machine ➤ Forward the error message to the Winterhalter service engineer
Err 23	Machine-internal error	<ul style="list-style-type: none"> ➤ Forward the error message to the Winterhalter service engineer

Display	Meaning	Remedy
 Flashes in red	<p>The temperature in the boiler or the tank is above 95°C.</p> <ul style="list-style-type: none"> ➤ Switch off the machine immediately. The error code Err 2 or Err 3 is displayed. 	<ul style="list-style-type: none"> ➤ Forward the error message to the Winterhalter service engineer
 Flashes in blue	<p>In case of inadequate pre-cleaning of the dish, dirt can get accumulated on the strainer and in the filter cassette such that the washing programme is disturbed.</p> <p>The circulating pumps switch off and the programme key (6) flashes in blue.</p>	<ul style="list-style-type: none"> ➤ Switch off the machine; the programme key continues to flash. ➤ Remove, clean and re-position the filters. ➤ The flashing stops after 1 minute. Switch on the machine again and operate it. ➤ Ensure better pre-cleaning to prevent any more malfunctions.

9.2 Malfunctions

Error	Possible cause	Remedy
Machine cannot be switched on	The local mains disconnecter is not switched on	Switch on the local mains disconnecter
	Local fuses defective	Repair the local fuses
Machine does not get filled	Machine door not closed completely	Close the machine door
	Water shut-off valve closed	Open the water shut-off valve
The dishes do not get clean	No or excessively low detergent dosing	Set the dosing amount as per the manufacturer's specifications
		Check the dosing lines (for kinks, breakage, ...)
		Replace the storage container
		Check the dosing device
	Dishes incorrectly sorted	Do not stack dishes one over the other
Nozzles of the wash arms blocked	Remove the wash arms and clean the nozzles	
Incorrect mode selected	Use the intensive mode	
Excessively low temperatures	Check the temperatures and if the desired values have not been attained, inform the Customer Service	
There is formation of layers on the dishes	In case of grease residues: The water is too hard	Check the external water preparation / set it correctly Clean thoroughly
	In case of starch residues: Excessively high temperatures during manual pre-cleaning (fizzy liquid)	Maximum temperature may be 30°C
The dishes do not dry on their own	No or excessively low rinse aid dosing	Set the dosing amount as per the manufacturer's specifications
		Check the dosing lines (for kinks, breakage, ...)
		Replace the storage container
		Check the dosing device

9.3 Malfunctions in machines with special equipment

Error	Possible cause	Remedy
Acoustic signal	Insufficient detergent or rinse aid	Refill the detergent or rinse aid
	Water treatment device requires regeneration	Regenerate the external water preparation system. Follow the notes in the relevant device documents.

10 Emission values

Noise

Workplace-related emission value L_{pAeq} as per DIN EN ISO 11202: < 70 dB

Exhaust air

Adhere to the VDI Guideline 2052 when designing the ventilation system.

11 Disposal

Contact your dealer so that the materials in the machine can be supplied back to the material circuit at the earliest.

12 Installation

Notes for the service engineer or dealer authorised by Winterhalter:

- Observe the connection diagram on page 46.
- The installation site must be frost-resistant so that the water supply systems do not freeze.
- Install the machine horizontally with the help of water-level.
- Adjust the base unevenness with the help of the height-adjustable machine feet.
- Water vapour escapes when opening the machine door which can cause the wood to get wet. If the furniture adjacent to the machine is made of wood, a vapour protection set must be installed. The same is applicable if the machine is installed under a worktop made of wood.

13 Water connection

Notes for the installer:

- Adhere to the connection diagram on page 46 along with the specifications for water supply temperature and water pressure.
- Connect the machine to the drinking water.
- Install a **main shut-off valve** in the water supply line near the machine such that it is easily accessible. It may not be behind the machine.
- The water-related safety should be as per DIN EN 61770. Thus, the machine can be connected to a fresh water line without an intermediate connection to another safety equipment.

- Use the supply pipe and the fine filter in the washer for water supply. The fine filter prevents particles from the water supply line entering the machine thus preventing extraneous rust on the cutlery and in the machine.
- The supply hose may not be shortened or damaged. Old existing hoses may not be re-used.
- Check whether the connections are tight.
- Use the drain pipe in the washer for draining water. The drain pipe may not be shortened or damaged.
- The washer is equipped with a drain pump. Refer to the connection diagram for the maximum pumping height.
- In case of water hardness of more than 3°d total hardness (GH), we recommend that you connect a water preparation system upstream so that the machine is not scaled and an optimum washing and drying result can be attained. The service engineer authorised by Winterhalter is always at your service.

14 Electrical connection

Notes for the electrician:



Danger

DANGER! Danger of life due to components that are energised!

Disconnect the machine from the mains during all electrical work and check if it is without power.

The machine and the relevant additional devices must be connected by an electrical company authorised by the relevant electricity supplier as per the locally applicable standards and regulations.

- Observe the connection diagram on page 46.
- Adhere to the rating plate and the circuit diagram.
- Check the effectiveness of all electrical protection systems.
- Connect the machine to a properly installed and checked protective conductor system.
- The electrical connection of the machine must correspond with the data of the rating plate.
- Secure the electrical connection of the machine as a separately secured circuit locally using inactive fuses or circuit breakers as per the total connecting loads on the rating plate.
- Mount a mains disconnecter and a fault current circuit breaker (FI) in the electrical supply line. These switches must switch off from all poles and must have the prescribed contact distance. The installation site must be near the machine and easily accessible.

14.1 Mains connection cable



Danger

DANGER! Danger of life due to components that are energised!

If the mains connecting line of this device is damaged, it must be replaced by the manufacturer or his Customer Service or another qualified person in order to prevent hazards.

Use a cable of the type H07 RN-F or a similar one.

Requirements for the mains connection cable

- Use of a cable of the type H07 RN-F or equivalent
- Cross-section and number of wires appropriate for voltage, fusing and overall connection value

14.2 Equipotential bonding

Integrate the machine and the relevant accessories and table systems into the local equipotential bonding system.

A connection screw marked with  is present behind the machine for equipotential bonding connection (► 15).

15 Position of the dosing points (detergent, rinse aid, defoamer)



Danger

DANGER! Danger of life due to components that are energised!
Get the dosing device installed and commissioned by a service engineer authorised by Winterhalter.
Disconnect the machine during all electrical work from the mains and check if it is without power.

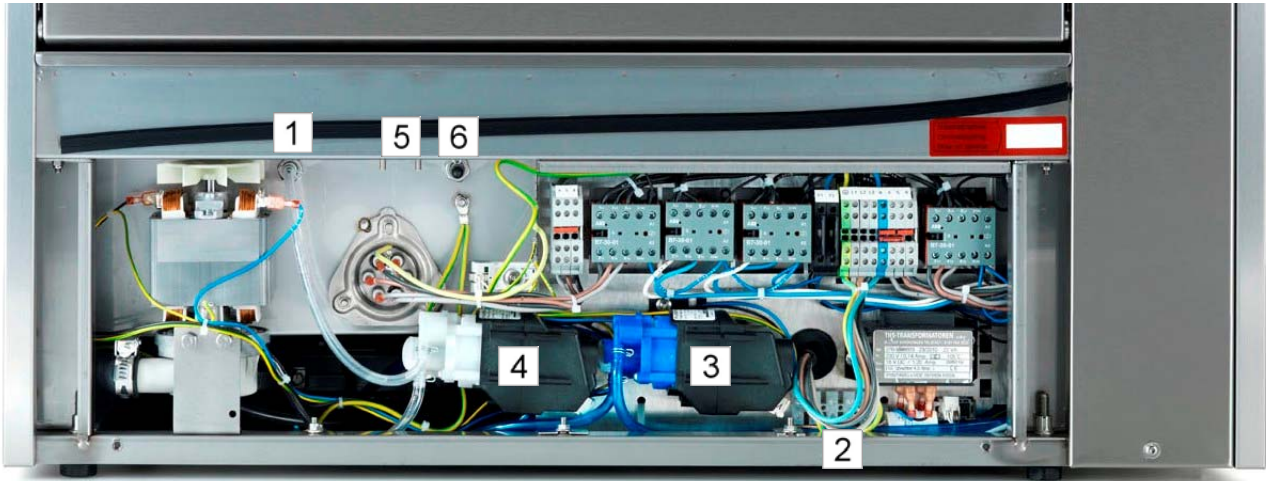

- 1 Dosing point of detergent; transparent hose
- 2 Take-over strip for the connection of external dosing devices (also see chapter 16)
- 3 Rinse aid dosing device
- 4 Detergent dosing device
- 5 Position for the defoamer dosing device (optional)
- 6 Dosing point of the defoamer

INFO: The dosing devices (no. 3 and 4) are not included in the scope of delivery of all machines.

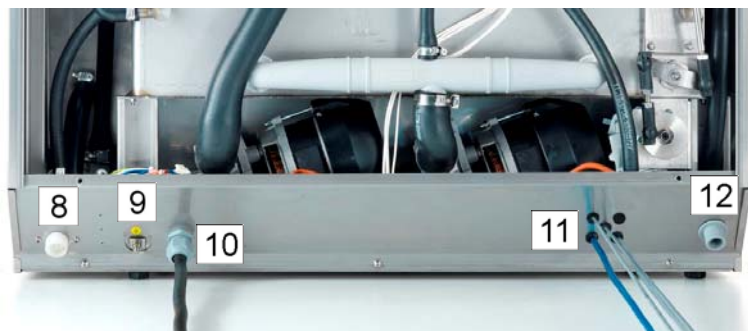

- 7 Dosing point of rinse aid; blue hose
- 8 Water connection
- 9 Connection screw for equipotential bonding
- 10 Electrical connection cable
- 11 Entry for detergent and rinse aid hoses
- 12 Water drain

16 Connecting external dosing devices

The terminal strip X3 for connecting external dosing devices is located in the plinth of the machine (position 2 in chapter 15). A maximum current drain of 0.5 A is permissible at the terminal strip.



Assignment of terminals (from left to right)

WASH	Permanent signal if the circulating pump is active
FILL	Signal depending on parameter P27
N*	Neutral conductor
L1*	Control phase
PE	Protective conductor

* secured with 4 ampere (medium inactive)

Setting parameter P27

P27=4: Permanent signal when filling the machine (after attaining the drying protection)

P27=5: Permanent signal when the supply solenoid valve is open

- Switch off the machine and the local mains disconnecter
- Connect the external dosing device to the terminal strip
- Switch on the local mains disconnecter

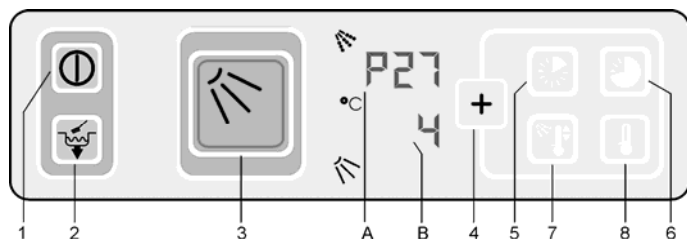

- Keep the keys 6 and 8 pressed and switch on the machine (press key 1). Release the key.
 - ⇒ P 27 is displayed on Display A
 - ⇒ Value 4 is displayed on Display B

If P27=4 is required:

- Press key 4 to save the value
 - ⇒ Key 3 lights up in red when saving

If P27=5 is required:

- Press key 8 to change the value from 4 to 5
- Press key 4 to save the changed value
 - ⇒ Key 3 lights up in red when saving

- Switch off the machine and switch it on again (key 1)
- Put the external dosing device into operation

17 Connection diagram GS 630

Dimensions

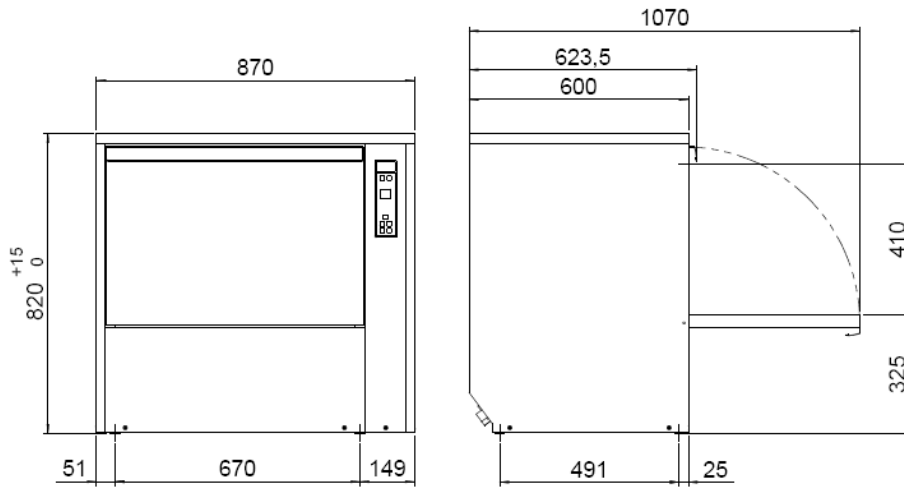

The machine height decreases by 4 mm when the feet are turned in completely.
For niche dimensions for the installation of the machine into a counter, see page 48.

Position of the connections (rear view)

Side view

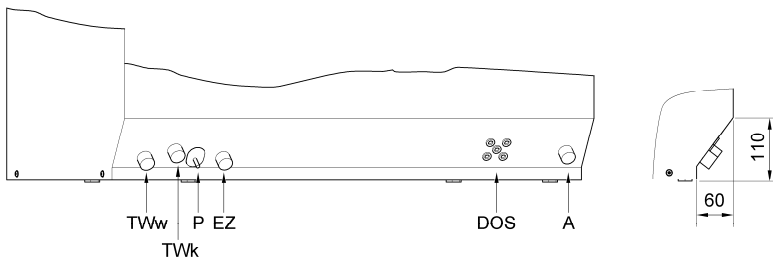

DOS	Port for hoses (detergent / rinse aid / defoamer) and cables
TWw	Drinking water connection (G 3/4", external thread)
TWk	Drinking water connection (G 3/4", external thread) (only in case of machines with cold water pre-wash (optional))
EZ	Electrical connection cable
P	Connection for local equipotential bonding system (⚡)
A	Waste water connection; drain pump installed

Accessories

Flexible supply hose;
Connect to point TWw / TWk

Flexible drain pipe;
connect to point A

Dirt trap;
Install it between the water shut-off
valve and the supply hose

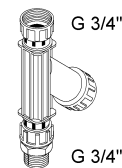
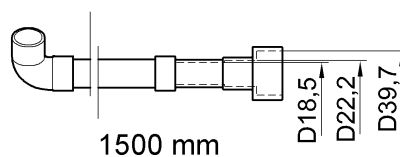
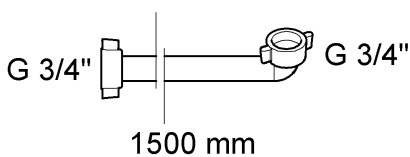

Local requirements

See page 47

18 Installation plan GS 630

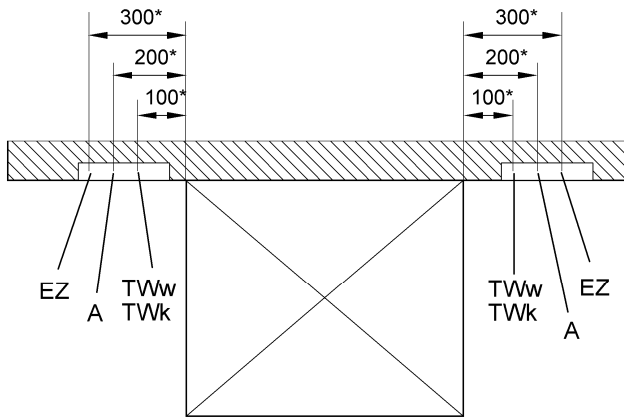

* Considering the local conditions, the exact dimensions must be determined.
For the dimensions of the machine, see page 46.

Important!

Provide the local connections on the left or the right beside the machine.
Observe both the local and country-specific regulations when conducting electrical and hydraulic connection work.
Only when the local mains disconnecter is switched off, the machine is without power.
Now bond the machine equipotentially.

Electrical supply pipe (Type H07 RN-F)

If the mains connecting line of this device is damaged, it must be replaced by the manufacturer or his Customer Service or another qualified person in order to prevent hazards.

Supply hose

Old existing hoses may not be re-used.
The supply hose may not be shortened or damaged.

TWw / TWk Water connection (G 3/4", external thread)

Position: appr. 400 mm above finished floor
Water quality: Drinking water in accordance with the Drinking Water Ordinance
Water inlet temperature: TWw: max. 60°C
TWk: Cold water in machines with cold water pre-wash
Water hardness: ≤ 3 °dH / 3.8 °e / 0.54 mmol/l
Flow pressure: TWw: 100-600 kPa; (1.0-6.0 bar)
TWk: 250-600 kPa; (2.5-6.0 bar) in machines with cold water pre-wash measured after a possibly upstream water treatment unit
Flow rate: TWw: min. 4 l/min
TWk: min. 15 l/min in machines with cold water pre-wash
Supply hose: included in delivery of the machine
The direct connection without protection fitting is allowed

A Waste water connection:

Position: max. 600 mm above finished floor
Construction: with siphon
Drain pipe: 1500 mm long (standard)

EZ Electrical connection

Position: appr. 300 mm above finished floor
Construction: Wall outlet for machines without power cord
Mains socket for machines with power cord
Mains disconnecter with all-pole mains disconnection and min. 3 mm contact opening width
Residual-current circuit breaker
Protection: depends on the total connected load of the machine (see page 48)
Electrical supply pipe: 3000 mm long; cross-section: 5 x 2.5 mm² (16A; 3 N~)
3000 mm long with power cord (Option); cross-section: 5 x 2.5 mm² (16A; 3 N~)
3000 mm long; cross-section: 4 x 4.0 mm² (20A, 25A; 3~)

19 Total connected loads GS 630

Voltage		Fuse	Tank heating	Boiler heating	Pumps + Control unit	Total connected load
380 – 415 V	3 N~	16 A	5.3 kW	5.3 kW	1.8 kW	7.1 kW
230 V	3 ~	20 A	4.9 kW	4.9 kW	1.7 kW	6.6 kW
380 – 415 V Australia	3 N~	16 A	6.5 kW	6.5 kW	1.8 kW	8.7 kW
200 V	3 ~	25 A	4.9 kW	4.9 kW	1.7 kW	6.6 kW

20 Niche dimensions GS 630

If the machine is to be installed into a counter, the following niche dimensions must be adhered to. It is not necessary to secure the machine in the counter. In the vicinity of the machine, use furniture that is appropriate for commercial areas in order to prevent damage to the machine due to steam.

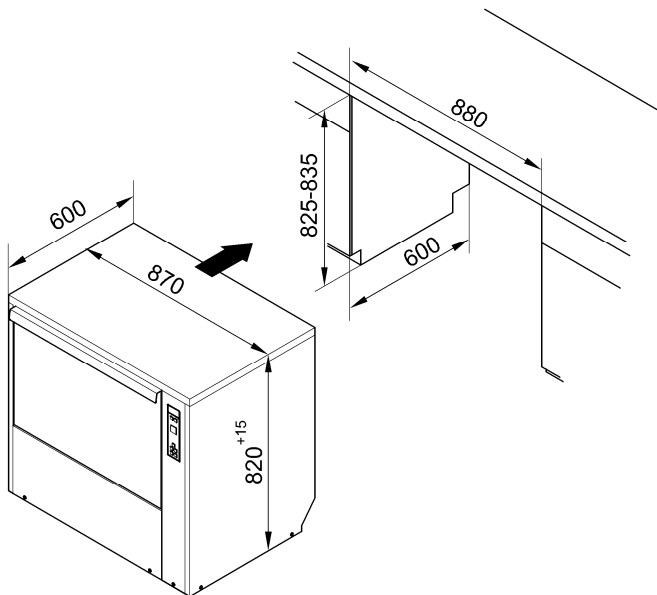

Dimensions in mm

For further machine dimensions, see page 46

EG / EC KONFORMITÄTSERKLÄRUNG DECLARATION OF CONFORMITY

Wir, We, Nous, Noi, Wij, Nosotros, Nós, My, My, Podjetje, Εμείς η, Vi, Mi a

Winterhalter Gastronom GmbH
Tettninger Straße 72
DE-88074 Meckenbeuren

erklären in alleiniger Verantwortung, dass das Produkt
declare under our sole responsibility that the product
déclarons sous notre seule responsabilité que le produit
dichiaro sotto la nostra piena responsabilità che il prodotto
verklaren als enig verantwoordelijke dat het product
declaramos bajo nuestra absoluta responsabilidad que el producto
Declaramos sob nossa única responsabilidade, que o produto
oświadczamy na własną odpowiedzialność, że produkt
prohlašujeme na vlastní zodpovednosť, že produkt
na lastno odgovornostjo izjavlja, da je izdelek
δηλώνουμε αποκλειστικά με δική μας ευθύνη, ότι το προϊόν
förklarar med enskilt ansvar att produkten
felelősségünk teljes tudatában kijelentjük, hogy a termék

Gewerbliche elektrische Spülmaschine,
Commercial electric dishwashing machines,
Lave-vaisselle professionnelle électrique,
Sistema di lavaggio elettronico industriale,
professionele vaatwasmachine,
lavavajillas eléctrico industrial,
Máquina de lavar loiça comercial eléctrica,
elektryczna zmywarka przemysłowa,
profesionální elektrická myčka
Profesionální elektrický pomívalni stroj,
Επαγγελματικό ηλεκτρικό πλυντήριο πιάτων,
elektrisk industridiskmaskin,
Professzionális elektromos mosogatógép,

GS 630

auf das sich diese Erklärung bezieht, mit den folgenden Normen übereinstimmt:
to which this declaration relates is in conformity with the following standards:
auquel se réfère cette déclaration est conforme aux normes :
al quale fa riferimento la presente dichiarazione, è conforme alle seguenti norme :
waarop deze verklaring betrekking heeft, met de volgende normen in overeenstemming is:
al que se refiere esta declaración, cumple las siguientes normas :
ao qual esta declaração diz respeito, está em conformidade com as seguintes normas:
do którego odnosi się to oświadczenie, jest zgodny z następującymi normami:
na kterou se vztahuje toto prohlášení, odpovídá níže uvedeným normám:
na katerega se nanaša ta izjava, skladen z naslednjimi standardi:
στο οποίο αναφέρεται αυτή η δήλωση, συμφωνεί με τα ακόλουθα πρότυπα:
vilken denna förklaring åsyftar, överensstämmer med följande normer:
amihez kapcsolódóan ezen nyilatkozat megfelel a következő szabványoknak:

EN 60335-1:02 + A1:04 + A2:06 + A11:04 + A12:06 + A13:08,
EN 60335-2-58:05 + A1:08,
EN 55014-1:06, EN 55014-2:97 + A1:01 + A2:08,
EN 61000-3-2:06, EN 61000-3-3:08, EN 62233:08, EN 61000-3-11:00, EN 61000-3-12:05

gemäß den Bestimmungen folgender Richtlinien:
following the provisions of Directives:
selon les conditions des directives suivantes :
Ai sensi alle disposizioni previste dalle seguenti direttive :
volgens de bepalingen van de volgende richtlijnen:
conforme a las disposiciones de las siguientes directivas:
de acordo com as disposições das seguintes directivas:
zgodnie z postanowieniami następujących dyrektyw:
na základě ustanovení následujících směrnic:
in je skladen z določili naslednjih direktiv :
σύμφωνα με τους κανονισμούς των ακόλουθων Οδηγιών:
enligt följande riktlinjers bestämmelser:
a következő irányelvek rendelkezéseinek:

2006/42/EC/MD (Machinery Directive); 2004/108/EC/EMC (Electromagnetic Compatibility)

Meckenbeuren, 25.02.2011

Bernhard Graeff
Technischer Leiter

89012995-01





Winterhalter Gastronom GmbH
Gewerbliche Spülsysteme

Tettnanger Straße 72
88074 Meckenbeuren
Telefon +49 (0) 75 42/4 02-0
Telefax +49 (0) 75 42/4 02-1 87

www.winterhalter.de
info@winterhalter.de

Winterhalter Gastronom GmbH
Commercial Dishwashing Systems

Tettnanger Straße 72
88074 Meckenbeuren · Germany
Telephon +49 (0) 75 42/4 02-0
Telefax +49 (0) 75 42/4 02-1 87

www.winterhalter.biz
info@winterhalter.biz